



Item: \_\_\_\_\_

Quantity: \_\_\_\_\_

Project: \_\_\_\_\_

**35 lb. Energy Efficient Fryer with Built-in Filter**

## **Delux Series**

**Models:**  REEF-35-2-XX  REEF-35-3-XX  REEF-35-4-XX  REEF-35-5-XX



REEF-35-2-EM

**Gas Type:**  Natural  LP

**Elevation (if above 2000 ft.):** \_\_\_\_\_

- EM - Electro mechanical thermostat (200°-400° F)
- DM2 - Two channel solid state digital control with melt cycle
- CM - 8 product computer control with individual programming capabilities for temperature and

**\*\* Includes a performance check by a certified food service technician**

### **Standard Features**

- Fully welded frame with lifetime warranty
- Energy Star Rated
- 54.4% energy efficient
- Less than 10 seconds recovery time
- 35 lb capacity per stainless steel tank
- Frying area each tank: 13 5/8" x 14"
- Shortening return through the wash hose
- 8 gpm filter pump with 6' power cord
- All welded stainless steel cabinet
- Cast iron burners rated at 24,000 BTU/hr each
- Twin fry baskets each tank with plastic coated handles for ease of handling
- 1 1/4" full port drain valve each tank
- Casters
- 25 sheets of filter envelope paper
- Five year limited (prorated) warranty on S/S tank

### **Options and Accessories**

- Royal Plus Filtration- Shortening returns thru the bottom of tank
- Royal Ultra-Plus Filtration- Shortening returns thru the bottom of tank and thru the wash hose
- SDS- Rear oil disposal port
- Fine mesh crumb screen with handle
- Triple filtration for heavy breading products
- Permafil filter screen in lieu of paper envelope
- Masterfil® reusable fabric filters
- Stainless-steel tank cover
- Stainless-steel side splash guard
- Filter tub cover
- Dump station with heat lamp
- 100 pack of filter paper
- 5" swivel casters
- 48" quick disconnect and restraining cable



**2 YEAR LIMITED, PARTS AND LABOR WARRANTY**

# 35 lb. Energy Efficient Fryer with Built-in Filter

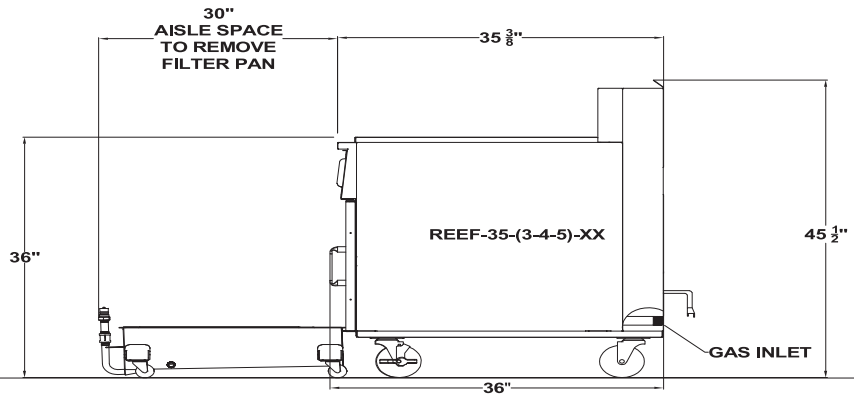
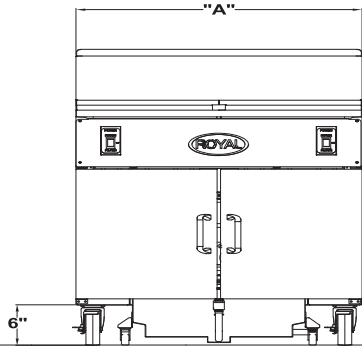
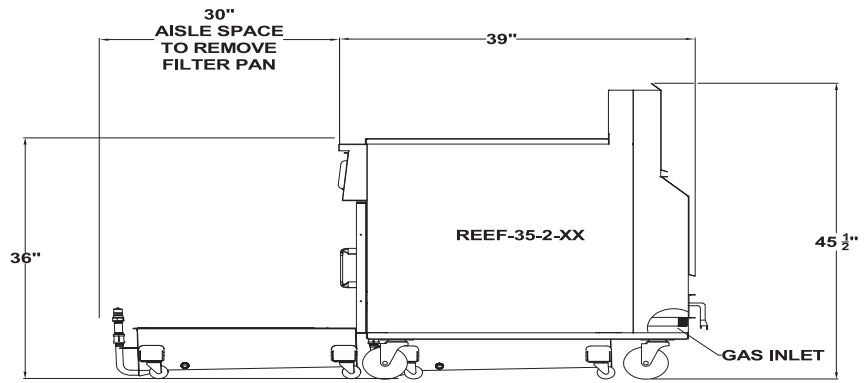
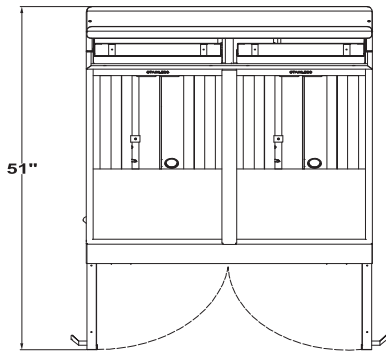

Model Number	Width "A"	Cooking Area Each Tank	Number of Burners/Tank	Total BTU Each Tank	Ship Weight
REEF-35-2-XX	31"	14" x 14"	3	72,000	510 lbs.
REEF-35-3-XX	46.5"	14" x 14"	3	72,000	680 lbs.
REEF-35-4-XX	62"	14" x 14"	3	72,000	870 lbs.
REEF-35-5-XX	77.5"	14" x 14"	3	72,000	1,060 lbs.

For dump station add 15 1/2" to width

Filter Electrical Requirements, 50/60

Volt / Phase	Amps
115V, 1PH	7 + .5 per tank

Gas Pressure:

4" W.C.	Natural Gas
11" W.C.	Propane

Clearances:

	Combustible	Non-Combustible
Rear	6"	0"
Sides	6"	0"

Gas Connection:

3/4" 1-2 tanks, 1" 3+ tanks NPT on the rear of fryer.  
No external pressure regulator required.

Specify type of gas and altitude, if over 2,000 feet,  
when ordering

Due to continuing product development to ensure best possible performance, these specifications are subject to change without prior notification.

**Royal Range of California, Inc.**  
3245 Corridor Dr. • Eastvale, CA 91752 • (800) 769-2414 • (951) 360-1600  
Fax: (951) 360-7500 • www.royalranges.com • sales@royalranges.com